

PART – A (PAPER-1)_PHYSICS

SECTION 1 (Maximum Marks : 12)

- This section contains **FOUR (04)** questions.
- Each question has **FOUR** options (A), (B), (C) and (D). **ONLY ONE** of these four options is the correct answer.
- For each question, choose the option corresponding to the correct answer.
- Answer to each question will be evaluated according to the following marking scheme:

Full Marks : +3 If **ONLY** the correct option is chosen;

Zero Marks : 0 If none of the options is chosen (i.e. the question is unanswered);

Negative Marks : 1 In all other cases.

1. A dimensionless quantity is constructed in terms of electronic charge e , permittivity of free space ϵ_0 , Planck's constant h , and speed of light c . If the dimensionless quantity is written as $e^\alpha \epsilon_0^\beta h^\gamma c^\delta$ and n is a non-zero integer, then $(\alpha, \beta, \gamma, \delta)$ is given by **[JEE Advanced 2024 MME]**

(A) $(2n, -n, -n, -n)$ (B) $(n, -n, -2n, -n)$ (C) $(n, -n, -n, -2n)$ (D) $(2n, -n, -2n, -2n)$

Ans. (A)

Sol. $[AT]^\alpha [M^{-1}L^{-3}T^4A^2]^\beta [ML^2T^{-1}]^\gamma [LT^{-1}]^\delta = 0$

$$\Rightarrow \alpha + 2\beta = 0$$

$$-\beta + \gamma = 0 \Rightarrow \alpha = -2\beta$$

$$-3\beta + 2\gamma + \delta = 0 \quad \gamma = \beta$$

$$\alpha + 4\beta - \gamma - \delta = 0 \quad \delta = \beta$$

$$(-2\beta, \beta, \beta, \beta)$$

2. An infinitely long wire, located on the z -axis, carries a current I along the $+z$ -direction and produces the magnetic field \vec{B} . The magnitude of the line integral $\int \vec{B} \cdot d\vec{l}$ along a straight line from the point $(-\sqrt{3}a, a, 0)$ to $(a, a, 0)$ is given by [μ_0 is the magnetic permeability of free space.] **[JEE Advanced 2024 EMF]**

(A) $7\mu_0 I / 24$ (B) $7\mu_0 I / 12$ (C) $\mu_0 I / 8$ (D) $\mu_0 I / 6$

Ans. (A)

Sol.

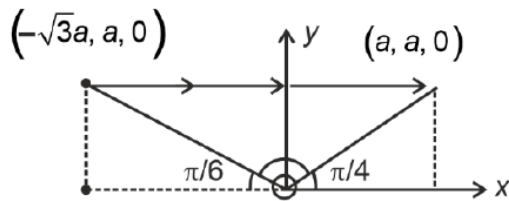

$$\theta = \pi - \frac{\pi}{4} - \frac{\pi}{6} \Rightarrow \theta = \frac{12\pi - 3\pi - 2\pi}{12} = \frac{7\pi}{12}$$

So, $\int \vec{B} \cdot d\vec{l}$ along the line is

$$\int \vec{B} \cdot d\vec{l} = -\frac{\mu_0(I)}{2\pi} \cdot \theta = \frac{\mu_0 I}{2\pi} \cdot \frac{7\pi}{12} \Rightarrow \left| \int \vec{B} \cdot d\vec{l} \right| = \frac{7\mu_0 I}{24}$$

3. Two beads, each with charge q and mass m , are on a horizontal, frictionless, non-conducting, circular hoop of radius R . One of the beads is glued to the hoop at some point, while the other one performs small oscillations about its equilibrium position along the hoop. The square of the angular frequency of the small oscillations is given by [ϵ_0 is the permittivity of free space.] **[JEE Advanced_2024_SHM]**

(A) $q^2 / (4\pi\epsilon_0 R^3 m)$ (B) $q^2 / (32\pi\epsilon_0 R^3 m)$ (C) $q^2 / (8\pi\epsilon_0 R^3 m)$ (D) $q^2 / (16\pi\epsilon_0 R^3 m)$

Ans. (B)

Sol. As the hoop mass is not given so it must not move or else its inertia must have some effect.

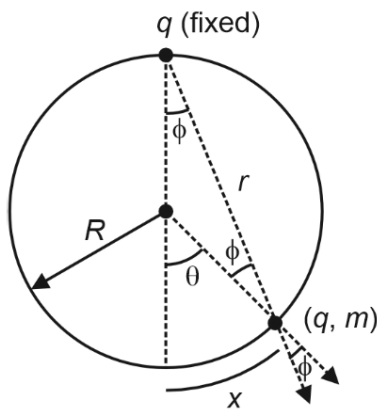

Here $r = 2R \cos \phi$

Also $\theta = 2\phi$

$$\Rightarrow \theta = \frac{\phi}{2}$$

And $\theta = \frac{x}{R}$

If θ is the small angular displacement of free charge, then $F(\phi) = \frac{Kq^2}{r^2}$

So, restoring force towards mean position is $F_{(R)} = \frac{Kq^2}{r^2} \sin \phi$

$$a_R = \frac{F_{(R)}}{m} = \frac{-Kq^2}{mr^2} \cdot \sin \phi = \frac{-Kq^2 \cdot \sin \phi}{m4R^2 \cos^2 \phi}$$

$$\Rightarrow a_R = -\frac{Kq^2}{4mR^2 \cos^2\left(\frac{\phi}{2}\right)} \cdot \sin\left(\frac{\theta}{2}\right) \approx \frac{-Kq^2}{4mR^2} \cdot \frac{1}{2} \cdot \frac{x}{R} = \omega^2 \cdot x$$

$$\text{So, } \omega^2 = \frac{q^2}{32\pi\epsilon_0 mR^3}$$

4. A block of mass 5 kg moves along the x -direction subject to the force $F = (-20x + 10)\text{N}$, with the value of x in metre. At time $t = 0\text{s}$, it is at rest at position $x = 1\text{m}$. The position and momentum of the block at $t = (\pi/4)\text{s}$ are **[JEE Advanced 2024 SHM]**

(A) $-0.5\text{ m}, 5\text{ kg m/s}$ (B) $0.5\text{ m}, 0\text{ kg m/s}$ (C) $0.5\text{ m}, -5\text{ kg m/s}$ (D) $-1\text{ m}, 5\text{ kg m/s}$

Ans. (C)

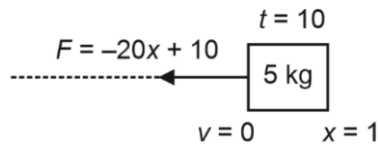

Sol.

Now,

$$a = -\frac{20x + 10}{5} = -4x + 2$$

$$a = \frac{v dv}{dx} = -4x + 2$$

$$\text{Hence } \int_0^v v dv = \int_1^x (-4x + 2) dx \rightarrow \frac{v^2}{2} = [-2x^2 + 2x]_1^x$$

$$v = -2\sqrt{x - x^2} \quad (\text{as particle starts moving in -ve } x \text{-direction})$$

$$\Rightarrow \frac{dx}{dt} = -2\sqrt{x - x^2} \rightarrow \int_{x=1}^{x=x} \frac{dx}{\sqrt{x - x^2}} = -2 \int_0^{\pi/4} dt$$

$$\sin^{-1}[2x - 1]_1^x = -\frac{\pi}{2}$$

$$x = \frac{1}{2} = 0.5\text{ m}$$

$$\text{Also, momentum} = mV = 5(V)_{x=\frac{1}{2}} = -5\text{ kg} \cdot \text{m/s}$$

SECTION 2 (Maximum Marks : 12)

- This section contains **THREE (03)** questions.
 - Each question has **FOUR** options (A), (B), (C) and (D). **ONE OR MORE THAN ONE** of these four option(s) is (are) correct answer(s).
 - For each question, choose the option(s) corresponding to (all) the correct answer(s).
 - Answer to each question will be evaluated according to the following marking scheme:
Full Marks : +4 **ONLY** if (all) the correct option(s) is(are) chosen;
Partial Marks : +3 If all the four options are correct but **ONLY** three options are chosen;
Partial Marks : + 2 If three or more options are correct but **ONLY** two options are chosen, both of which are correct;
Partial Marks : +1 If two or more options are correct but **ONLY** one option is chosen and it is a correct option;
Zero Marks : 0 If none of the options is chosen (i.e. the question is unanswered);
Negative Marks : -2 In all other cases.
-

5. A particle of mass m is moving in a circular orbit under the influence of the central force $F(r) = -kr$, corresponding to the potential energy $V(r) = kr^2 / 2$, where k is a positive force constant and r is the radial distance from the origin. According to the Bohr's quantization rule, the angular momentum of the particle is given by $L = nh$, where $h = h / (2\pi)$, h is the Planck's constant, and n a positive integer. If v and E are the speed and total energy of the particle, respectively, then which of the following expression(s) is(are) correct? [JEE Advanced_2024_MP]

(A) $r^2 = nh\sqrt{\frac{1}{mk}}$ (B) $v^2 = nh\sqrt{\frac{k}{m^3}}$ (C) $\frac{L}{mr^2} = \sqrt{\frac{k}{m}}$ (D) $E = \frac{nh}{2} \sqrt{\frac{k}{m}}$

Ans. (A, B, C)

Sol. $L = mvr = nh$, also, $\frac{mv^2}{r} = kr$

$$mv^2 = kr^2$$

$$m^2v^2 = mkr^2$$

$$mv = \sqrt{mkr^2}$$

$$mvr = r^2\sqrt{mk}$$

$$nh = r^2\sqrt{mk}$$

$$\frac{nh}{\sqrt{mk}} = r^2$$

Option (A) is correct

$$\text{Also, } v^2 = \frac{kr^2}{m}$$

$$= \frac{nh}{\sqrt{mk}} \cdot \frac{k}{m} v^2 = nh \sqrt{\frac{k}{m^3}}$$

Option (B) is correct

Now,

$$\text{T.E} = E = \frac{1}{2}kr^2 + \frac{1}{2}kr^2$$

$$E = kr^2$$

$$= k \frac{nh}{\sqrt{mk}} = nh \sqrt{\frac{k}{m}}$$

Option (D) is incorrect

$$\Rightarrow \frac{L}{mr^2} = \frac{h\sqrt{mk}}{mnh}$$

$$\frac{L}{mr^2} = \sqrt{\frac{k}{m}}$$

Option (C) is correct

6. Two uniform strings of mass per unit length μ and 4μ , and length L and $2L$, respectively, are joined at point O , and tied at two fixed ends P and Q , as shown in the figure. The strings are under a uniform tension T . If we define the frequency $\nu_0 = \frac{1}{2L} \sqrt{\frac{T}{\mu}}$, which of the following statement (s) is (are) correct?

[JEE Advanced_2024_STW]

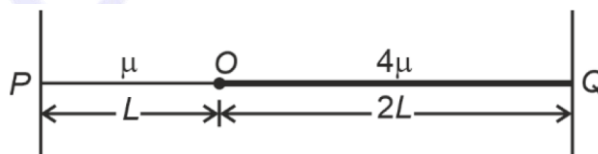

- (A) With a node at O , the minimum frequency of vibration of the composite string is ν_0
- (B) With an antinode at O , the minimum frequency of vibration of the composite string is $2\nu_0$
- (C) When the composite string vibrates at the minimum frequency with a node at O , it has 6 nodes, including the end nodes
- (D) No vibrational mode with an antinode at O is possible for the composite string

Ans. (A, C, D)

Sol. With node at O

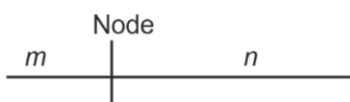

$$v = \sqrt{\frac{T}{\mu}} \quad v' = \sqrt{\frac{T}{4\mu}} = \frac{1}{2}v$$

$$\Rightarrow m \frac{1}{2l} \sqrt{\frac{T}{\mu}} = n \frac{1}{2(2l)} \sqrt{\frac{T}{4\mu}}$$

$$\Rightarrow m = \frac{n}{2} \times \frac{1}{2}$$

$$\Rightarrow \frac{m}{n} = \frac{1}{4}$$

$$\therefore m = 1, n = 4$$

With antinode at O

$$m \frac{1}{4l} \sqrt{\frac{T}{\mu}} = n \frac{1}{4(2l)} \sqrt{\frac{T}{4\mu}}$$

$$\Rightarrow \frac{m}{n} = \frac{1}{2} \times \frac{1}{2} \Rightarrow \frac{m}{n} = \frac{1}{4}$$

$$\therefore m = 1 \quad f_{\min} = 1 \frac{1}{4l} \sqrt{\frac{T}{\mu}} = \frac{v_0}{2}$$

(B is wrong)

Also, when node at O .

Total nodes = 6

(C is correct)

A, C, D are correct

7. A glass beaker has a solid, plano-convex base of refractive index 1.60, as shown in the figure. The radius of curvature of the convex surface (SPU) is 9cm, while the planar surface (STU) acts as a mirror. This beaker is filled with a liquid of refractive index n up to the level QPR . If the image of a point object O at a height of h (OT in the figure) is formed onto itself, then, which of the following option(s) is (are) correct?

[JEE Advanced_2024_GO]

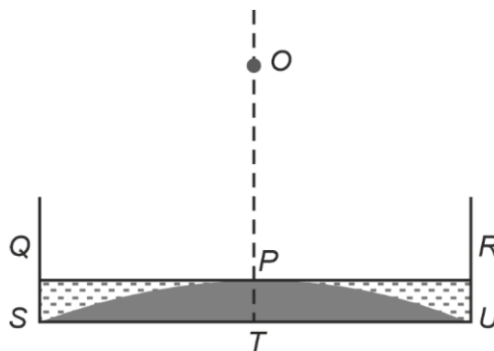

- (A) For $n = 1.42, h = 50$ cm (B) For $n = 1.35, h = 36$ cm
 (C) For $n = 1.45, h = 65$ cm (D) For $n = 1.48, h = 85$ cm

Ans. (A, B)

Sol.

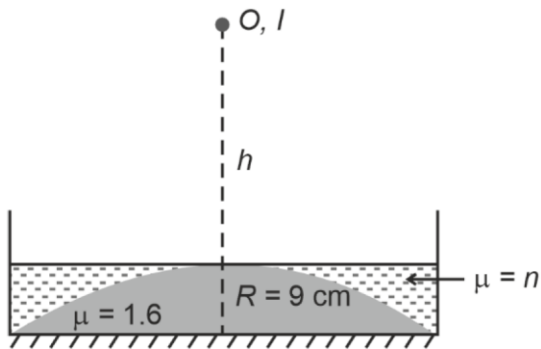

For image to coincide with object

$$-h = 2(f_{\text{net}})$$

$$\Rightarrow -\frac{1}{f_{\text{net}}} = 2\left(\frac{1}{f_{\text{liq}}}\right) + 2\left(\frac{1}{f_{\text{lens}}}\right) + \left(\frac{-1}{f_{\text{mirror}}}\right)$$

$$-\frac{1}{f_{\text{net}}} = 2\left(\frac{n-1}{-9}\right) + 2\left(\frac{0.6}{9}\right) + \left(-\frac{1}{\infty}\right)$$

From (i) and (ii)

$$h = \frac{9}{(1.6 - n)}$$

For $n = 1.42$, $h = 50$ cm (A is correct)

For $n = 1.35$, $h = 36$ cm (B is correct)

For $n = 1.45$, $h = 60$ cm (C is incorrect)

For $n = 1.48$, $h = 75$ cm (D is incorrect)

SECTION 3 (Maximum Marks : 24)

- This section contains **SIX (06)** questions.
- The answer to each question is a **NON-NEGATIVE INTEGER**.
- For each question, enter the correct integer corresponding to the answer using the mouse and the on-screen virtual numeric keypad in the place designated to enter the answer.
- Answer to each question will be evaluated according to the following marking scheme:

Full Marks : +4 If **ONLY** the correct integer is entered;

Zero Marks : 0 In all other cases.

8. The specific heat capacity of a substance is temperature dependent and is given by the formula $C = kT$, where k is a constant of suitable dimensions in SI units, and T is the absolute temperature. If the heat required to raise the temperature of 1 kg of the substance from -73°C to 27°C is nk , the value of n is ____.
- [Given: $0\text{K} = -273^\circ\text{C}$.] [JEE Advanced_2024_HT]

Ans. (25000)

Sol. $C = \frac{dQ/m}{dT}$

$$\Rightarrow dQ = m \cdot C \cdot dT = 1 \cdot kT dT$$

$$Q = \int_{200}^{300} kT dT = \frac{k}{2} [300^2 - 200^2]$$

$$= \frac{10^4}{2} \cdot k \cdot 5$$

$$= 25000k$$

$$\Rightarrow n = 25000$$

9. A disc of mass M and radius R is free to rotate about its vertical axis as shown in the figure. A battery operated motor of negligible mass is fixed to this disc at a point on its circumference. Another disc of the same mass M and radius $R/2$ is fixed to the motor's thin shaft. Initially, both the discs are at rest. The motor is switched on so that the smaller disc rotates at a uniform angular speed ω . If the angular speed at which the large disc rotates is ω/n , then the value of n is ____.
- [JEE Advanced_2024_RBD]

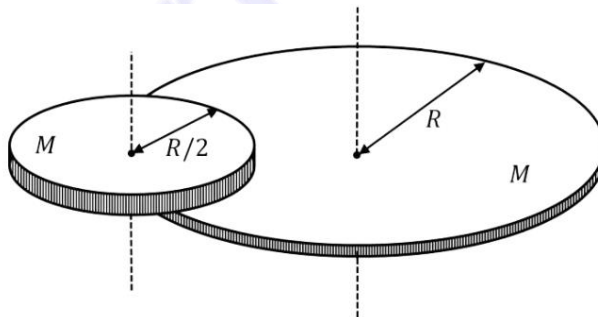

Ans. (12)

Sol. Conserving angular momentum of the system (bigger disc + smaller disc) about the symmetric axis of bigger disc:

$$\frac{MR^2}{2} \omega' + M \cdot R\omega' \cdot R + \frac{M(R/2)^2}{2} \omega = 0$$

Where ω' : required angular speed.

$$\Rightarrow \frac{3}{2} MR^2 \omega' = \frac{-MR^2 \omega}{8}$$

$$\Rightarrow \omega' = -\frac{\omega}{12}$$

$$\Rightarrow n = 12$$

10. A point source S emits unpolarized light uniformly in all directions. At two points A and B , the ratio $r = I_A / I_B$ of the intensities of light is 2. If a set of two polaroids having 45° angle between their pass-axes is placed just before point B , then the new value of r will be _____. **[JEE Advanced_2024_SOW]**

Ans. (8)

Sol. $I \propto \frac{1}{l^2}$

Where l : distance from point source.

$$\Rightarrow \frac{I_A}{I_B} = \frac{I_B^2}{I_A^2} = 2$$

$$\Rightarrow I_B = \sqrt{2}I_A \quad \dots(1)$$

Also, due to polaroids:

$$I'_B = \frac{I_B}{2} \cos^2 45^\circ = \frac{I_B}{4}$$

$$\Rightarrow I'_B = \frac{I_B}{4} \quad \dots(2)$$

\Rightarrow Ratio becomes 4 times.

$$\Rightarrow r_{\text{new}} = 8$$

11. A source (S) of sound has frequency 240Hz. When the observer (O) and the source move towards each other at a speed v with respect to the ground (as shown in Case 1 in the figure), the observer measures the frequency of the sound to be 288Hz. However, when the observer and the source move away from each other at the same speed v with respect to the ground (as shown in Case 2 in the figure), the observer measures the frequency of sound to be n Hz. The value of n is _____. **[JEE Advanced_2024_SOW]**

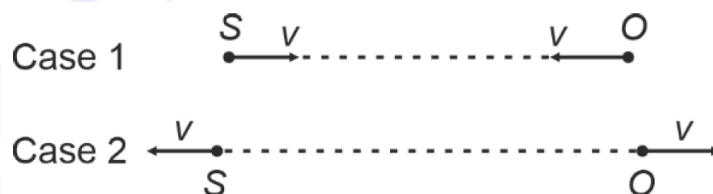

Ans. (200)

Sol. For Case 1 :

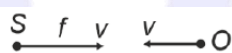

$$f_{\text{app}} = f \left(\frac{c+v}{c-v} \right) \Rightarrow 288 = 240 \left(\frac{c+v}{c-v} \right) \quad \dots\dots(i)$$

For Case 2 :



$$f_{\text{app}} = f \left(\frac{c-v}{c+v} \right) = 240 \left(\frac{c-v}{c+v} \right) \quad \dots\dots(ii)$$

From (i) and (ii)

$$288 \times f_{\text{app}} = 240 \left(\frac{c+v}{c-v} \right) \times 240 \left(\frac{c-v}{c+v} \right)$$

$$288 f_{\text{app}} = 240 \times 240$$

$$f_{\text{app}} = 200 \text{ Hz}$$

12. Two large, identical water tanks, 1 and 2, kept on the top of a building of height H , are filled with water up to height h in each tank. Both the tanks contain an identical hole of small radius on their sides, close to their bottom. A pipe of the same internal radius as that of the hole is connected to tank 2, and the pipe ends at the ground level. When the water flows the tanks 1 and 2 through the holes, the times taken to empty the tanks are t_1 and t_2 , respectively. If $H = \left(\frac{16}{9} \right) h$, then the ratio t_1 / t_2 is _____. [JEE Advanced_2024_FM]

Ans. (3)

Sol. In general case

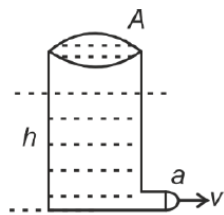

$$a\sqrt{2gh} = -A \frac{dh}{dt} \Rightarrow dt = -\frac{A}{a} \frac{dh}{\sqrt{2gh}}$$

$$T = \int dt = \frac{-2A}{a\sqrt{2g}} (\sqrt{h_f} - \sqrt{h_i})$$

$$T = \frac{2A}{a\sqrt{2g}} (\sqrt{h_i} - \sqrt{h_f})$$

For tank 1 :

$$h_i = h, h_f = 0$$

$$T_1 = \frac{2A}{a\sqrt{2g}} (\sqrt{h})$$

For tank 2 :

$$h_f = \frac{16h}{9}, h_i = h + H = \frac{25h}{9}$$

$$T_2 = \frac{2A\sqrt{h}}{a\sqrt{2g}} \left(\frac{5}{3} - \frac{4}{3} \right) = \frac{2A\sqrt{h}}{a\sqrt{2g}} \times \frac{1}{3}$$

$$\frac{T_1}{T_2} = 3$$

13. A thin uniform rod of length L and certain mass is kept on a frictionless horizontal table with a massless string of length L fixed to one end (top view is shown in the figure). The other end of the string is pivoted to a point O . If a horizontal impulse P is imparted to the rod at a distance $x = L/n$ from the mid-point of the rod (see figure), then the rod and string revolve together around the point O , with the rod remaining aligned with the string. In such a case, the value of n is _____. [JEE Advanced_2024_RBD]

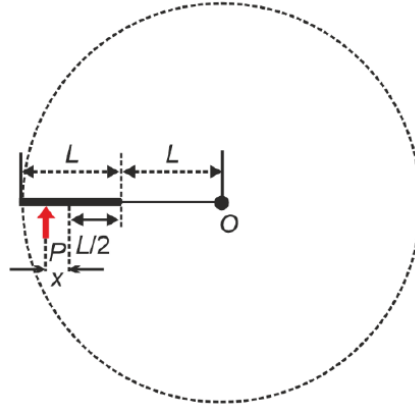

Ans. (18)

Sol.

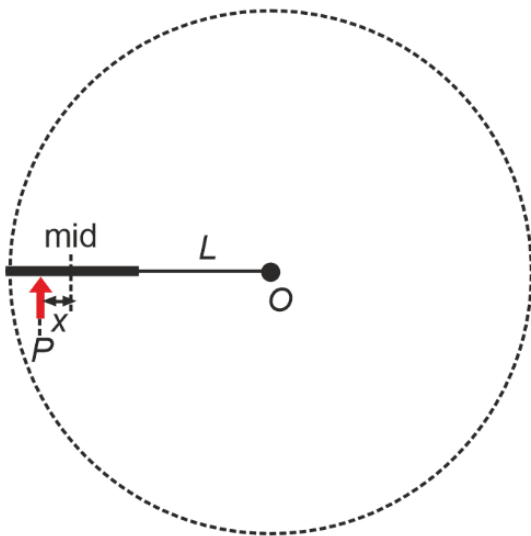

$$\text{M.I. of rod about centre } (O) = \frac{mL^2}{12} + m\left(L + \frac{L}{2}\right)^2$$

$$I_0 = \frac{7mL^2}{3}$$

Since rod is in pure rotation about 'O'

$$\text{So, angular impulse} = P\left(x + \frac{3L}{2}\right) = I_0\omega_0 \quad \dots(i)$$

$$\text{and linear impulse} = mv_c \quad \dots(ii)$$

where $V_c = \frac{3L}{2} \omega_0$ (iii)

(20 m (i)) $m \left(\frac{3L}{2} \omega_0 \right) \left(x + \frac{3L}{2} \right) = \frac{7}{3} mL^2 \cdot \omega_0$

$x + \frac{3L}{2} = \frac{14}{9} L$

$x = \frac{L}{18}$

SECTION 4 (Maximum Marks : 12)

- This section contains **FOUR (04)** Matching List Sets.
- Each set has **ONE** Multiple Choice Question.
- Each set has **TWO** lists: **List-I** and **List-II**.
- **List-I** has **Four** entries (P), (Q), (R) and (S) and **List-II** has **Five** entries (1), (2), (3), (4) and (5).
- **FOUR** options are given in each Multiple Choice Question based on **List-I** and **List-II** and **ONLY ONE** of these four options satisfies the condition asked in the Multiple Choice Question.
- Answer to each question will be evaluated according to the following marking scheme:
 Full Marks : +3 **ONLY** if the option corresponding to the correct combination is chosen;
 Zero Marks : 0 If none of the options is chosen (i.e. the question is unanswered);
 Negative Marks : 1 In all other cases.

14. One mole of a monatomic ideal gas undergoes the cyclic process $J \rightarrow K \rightarrow L \rightarrow M \rightarrow J$, as shown in the $P-T$ diagram.

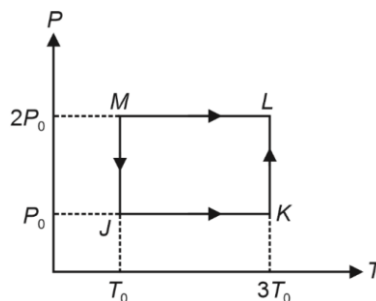

Match the quantities mentioned in List-I with their values in List-II and choose the correct option.

[R is the gas constant.] [JEE Advanced_2024_KTG]

	List-I		List-II
(P)	Work done in the complete cyclic process	(1)	$RT_0 - 4RT_0 \ln 2$
(Q)	Change in the internal energy of the gas in the process JK	(2)	0
(R)	Heat given to the gas in the process KL	(3)	$3RT_0$
(S)	Change in the internal energy of the gas in the process MJ	(4)	$-2RT_0 \ln 2$
		(5)	$-3RT_0 \ln 2$

(A) $P \rightarrow 1; Q \rightarrow 3; R \rightarrow 5; S \rightarrow 4$

(B) $P \rightarrow 4; Q \rightarrow 3; R \rightarrow 5; S \rightarrow 2$

(C) $P \rightarrow 4; Q \rightarrow 1; R \rightarrow 2; S \rightarrow 2$

(D) $P \rightarrow 2; Q \rightarrow 5; R \rightarrow 3; S \rightarrow 4$

Ans. (B)

Sol. From $M \rightarrow J$, isothermal

$$W = nRT \ln 2$$

$$= RT_0 \ln 2$$

$$\Delta U = 0$$

From $J \rightarrow K$, isobaric

$$W = nR(3T_0 - T_0)$$

$$W = 2RT_0$$

$$\Delta U = nC_v \Delta T$$

$$= \frac{3R}{2} \times 2T_0 = 3RT_0$$

From $K \rightarrow L$, isothermal

$$W = -nR(3T_0) \ln 2$$

$$W = -3RT_0 \ln 2$$

$$\Delta U = 0$$

$$Q = -3RT_0 \ln 2$$

From $L \rightarrow M$, isobaric

$$W = nR(T_0 - 3T_0)$$

$$W = -2RT_0$$

$$\Delta U = nC_v \Delta T$$

$$= n \times \frac{3R}{2} \times (-2T_0) = -3RT_0$$

For P :-

$$W_{\text{net}} = RT_0 \ln 2 + 2RT_0 - 3RT_0 \ln 2 - 2RT_0$$

$$= -2RT_0 \ln 2$$

$$P \rightarrow 4$$

$$\text{for } Q \rightarrow 3$$

$$\text{for } R \rightarrow 5$$

$$\text{for } S \rightarrow 2$$

15. Four identical thin, square metal sheets, $S_1, S_2, S_3,$ and $S_4,$ each of side a are kept parallel to each other with equal distance $d (\ll a)$ between them, as shown in the figure. Let $C_0 = \epsilon_0 a^2 / d$, where ϵ_0 is the permittivity of free space.

[JEE Advanced_2024_CPC]

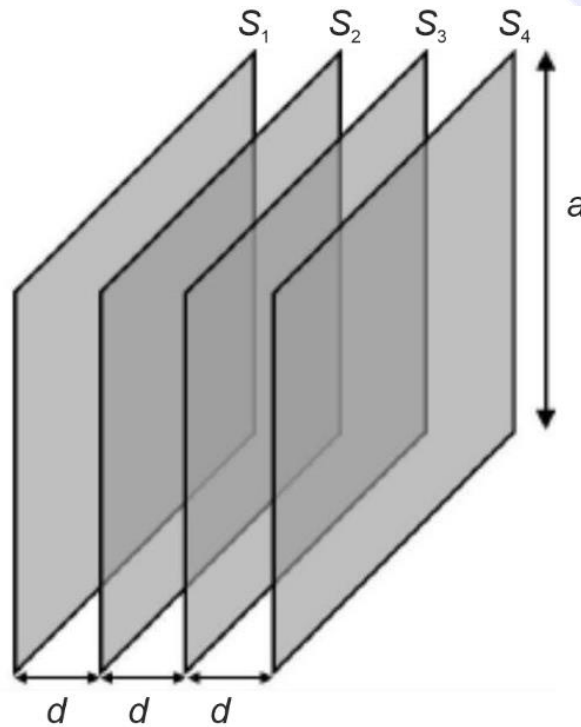

Match the quantities mentioned in List-I with their values in List-II and choose the correct option.

	List-I		List-II
(P)	The capacitance between S_1 and S_4 , with S_2 and S_3 not connected, is	(1)	$3C_0$
(Q)	The capacitance between S_1 and S_4 , with S_2 shorted to S_3 , is	(2)	$C_0/2$
(R)	The capacitance between S_1 and S_3 , with S_2 shorted to S_4 , is	(3)	$C_0/3$
(S)	The capacitance between S_1 and S_2 , with S_3 shorted to S_1 , and S_2 shorted to S_4 , is	(4)	$2C_0/3$
		(5)	$2C_0$

(A) $P \rightarrow 3; Q \rightarrow 2; R \rightarrow 4; S \rightarrow 5$

(B) $P \rightarrow 2; Q \rightarrow 3; R \rightarrow 2; S \rightarrow 1$

(C) $P \rightarrow 3; Q \rightarrow 2; R \rightarrow 4; S \rightarrow 1$

(D) $P \rightarrow 3; Q \rightarrow 2; R \rightarrow 2; S \rightarrow 5$

Ans. (C)

Sol. For P

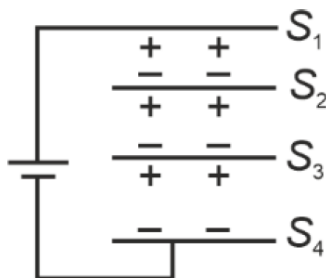

All are in series

$$C_{eq} = \frac{C_0}{3}$$

$P \rightarrow (3)$

For Q

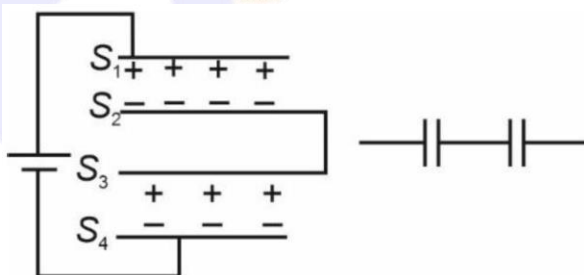

$$C_{eq} = \frac{C_0}{2}$$

$Q \rightarrow (2)$

For R

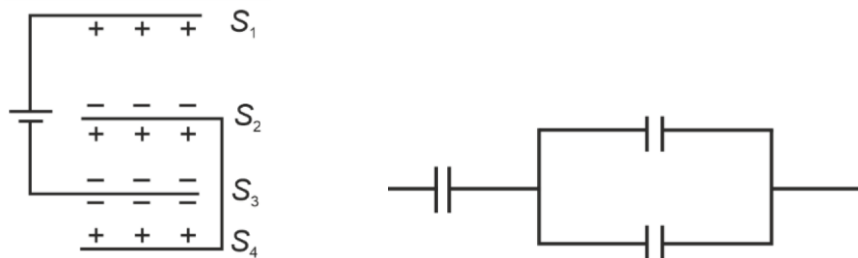

$$C_{\text{eq}} = \frac{2C}{3}$$

R \rightarrow (4)

For S

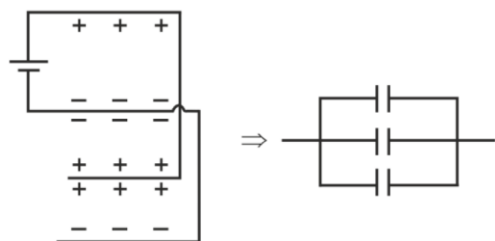

$$\Rightarrow C_{\text{eq}} = 3C_0$$

S \rightarrow (1)

16. A light ray is incident on the surface of a sphere of refractive index n at an angle of incidence θ_0 . The ray partially refracts into the sphere with angle of refraction ϕ_0 and then partly reflects from the back surface. The reflected ray then emerges out of the sphere after a partial refraction. The total angle of deviation of the emergent ray with respect to the incident ray is α . Match the quantities mentioned in List-I with their values in List-II and choose the correct option. [JEE Advanced_2024_GO]

	List-I		List-II
(P)	If $n = 2$ and $\alpha = 180^\circ$, then all the possible values of θ_0 will be	(1)	30° and 0°
(Q)	If $n = \sqrt{3}$ and $\alpha = 180^\circ$, then all the possible values of θ_0 will be	(2)	60° and 0°
(R)	If $n = \sqrt{3}$ and $\alpha = 180^\circ$, then all the possible values of ϕ_0 will be	(3)	45° and 0°
(S)	If $n = \sqrt{2}$ and $\theta_0 = 45^\circ$, then all the possible values of α will be	(4)	150°
		(5)	0°

(A) P \rightarrow 5; Q \rightarrow 2; R \rightarrow 1; S \rightarrow 4

(B) P \rightarrow 5; Q \rightarrow 1; R \rightarrow 2; S \rightarrow 4

(C) P \rightarrow 3; Q \rightarrow 2; R \rightarrow 1; S \rightarrow 4

(D) P \rightarrow 3; Q \rightarrow 1; R \rightarrow 2; S \rightarrow 5

Ans. (A)

Sol.

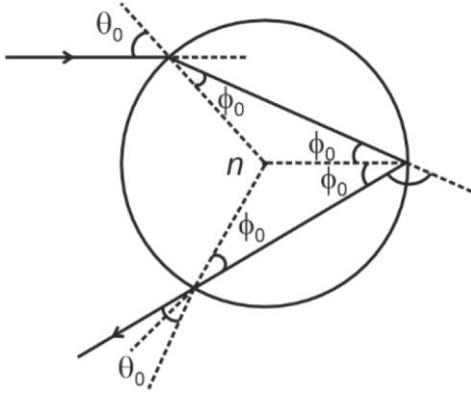

$$\alpha = (\theta_0 - \phi_0) + (\pi - 2\phi_0) + (\theta_0 - \phi_0)$$

$$\alpha = \pi + 2\theta_0 - 4\phi_0 \quad \dots(i)$$

$$\sin \theta_0 = n \sin \phi_0 \quad \dots(ii)$$

For (P)

$$n = 2, \alpha = 180$$

$$\text{if } \alpha = \pi, 2\theta_0 - 4\phi_0 = 0$$

$$\theta_0 = 2\phi_0$$

$$\sin \theta_0 = 2 \sin \left(\frac{\theta_0}{2} \right)$$

$$P \rightarrow (5)$$

$$\text{For } Q, n = \sqrt{3}, \alpha = 180$$

$$\theta_0 = 2\phi_0$$

$$Q \rightarrow (2)$$

$$\sin \theta_0 = \sqrt{3} \sin \left(\frac{\theta_0}{2} \right)$$

$$\theta_0 = 60, 0^\circ$$

17. The circuit shown in the figure contains an inductor L , a capacitor C_0 , a resistor R_0 and an ideal battery. The circuit also contains two keys K_1 and K_2 . Initially, both the keys are open and there is no charge on the capacitor. At an instant, key K_1 is closed and immediately after this the current in R_0 is found to be I_1 . After a long time, the current attains a steady state value I_2 . Thereafter, K_2 is closed and simultaneously K_1 is opened and the voltage across C_0 oscillates with amplitude V_0 and angular frequency ω_0 .

[JEE Advanced_2024_CEL]

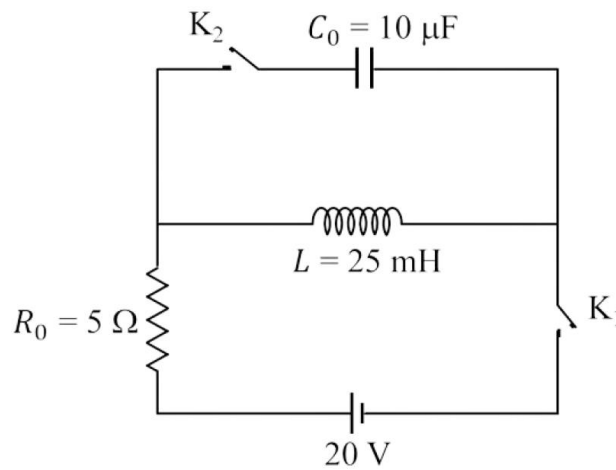

Match the quantities mentioned in List-I with their values in List-II and choose the correct option.

	List-I		List-II
(P)	The value of i_1 in Ampere is	(1)	0
(Q)	The value of i_2 in Ampere is	(2)	2
(R)	The value of ω_0 in kilo-radians/s is	(3)	4
(S)	The value of V_0 in Volt is	(4)	20
		(5)	200

(A) P \rightarrow 1; Q \rightarrow 3; R \rightarrow 2; S \rightarrow 5

(B) P \rightarrow 1; Q \rightarrow 2; R \rightarrow 3; S \rightarrow 5

(C) P \rightarrow 1; Q \rightarrow 3; R \rightarrow 2; S \rightarrow 4

(D) P \rightarrow 2; Q \rightarrow 5; R \rightarrow 3; S \rightarrow 4

Ans. (A)

Sol. Just after closing K_1

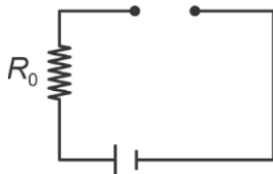

$$i_1 = 0, \quad P \rightarrow (1)$$

After long time

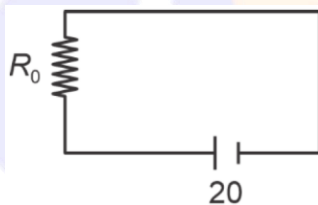

$$i_2 = \frac{20}{5} = 4 \text{ A}, \quad Q \rightarrow (3)$$

After opening K_1 & closing K_2

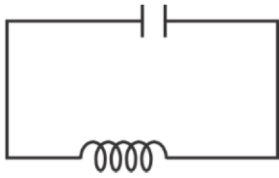

$$\omega = \frac{1}{\sqrt{LC}} = \frac{1}{\sqrt{25 \times 10^{-3} \times 10 \times 10^{-6}}}$$

$$\omega = 2000 \text{ rad/s}$$

$$\omega = 2 \text{ krad/s}$$

R → (2)

$$i_0 = 4$$

$$Q_0 = \frac{i_0}{\omega} = \frac{4}{2 \times 10^3} = 2 \text{mC}$$

$$\therefore V_0 = \frac{Q_0}{C} = \frac{2 \times 10^{-3}}{10} = 200$$

S → (5)