

JEE-MAIN EXAM JANUARY, 2024

Date: - 27-01-2024 (SHIFT-1)

PHYSICS**SECTION-A**

1. Position of an ant (S in metres) moving in $Y - Z$ plane is given by $S = 2t^2\hat{j} + 5t\hat{k}$ (where t is in second). The magnitude and direction of velocity of the ant at $t = 1$ s will be :
- (1) 16 m/s in y -direction (2) 4 m/s in x -direction
 (3) 9 m/s in z -direction (4) 4 m/s in y -direction
2. Given below are two statements :
- Statement (I) :Viscosity of gases is greater than that of liquids.
 Statement (II) : Surface tension of a liquid decreases due to the presence of insoluble impurities.
 In the light of the above statements, choose the most appropriate answer from the options given below:
- (1) Statement I is correct but statement II is incorrect
 (2) Statement I is incorrect but Statement II is correct
 (3) Both Statement I and Statement II are incorrect
 (4) Both Statement I and Statement II are correct
3. If the refractive index of the material of a prism is $\cot\left(\frac{A}{2}\right)$, where A is the angle of prism then the angle of minimum deviation will be
- (1) $\pi - 2A$ (2) $\frac{\pi}{2} - 2A$ (3) $\pi - A$ (4) $\frac{\pi}{2} - A$
4. A proton moving with a constant velocity passes through a region of space without any change in its velocity. If \vec{E} and \vec{B} represent the electric and magnetic fields respectively, then the region of space may have :
- (A) $E = 0, B = 0$ (B) $E = 0, B \neq 0$ (C) $E \neq 0, B = 0$ (D) $E \neq 0, B \neq 0$
- Choose the most appropriate answer from the options given below :
- (1)(A), (B) and (C) only (2) (A), (C) and (D) only
 (3) (A), (B) and (D) only (4) (B), (C) and (D) only
5. The acceleration due to gravity on the surface of earth is g . If the diameter of earth reduces to half of its original value and mass remains constant, then acceleration due to gravity on the surface of earth would be :
- (1) $g/4$ (2) $2g$ (3) $g/2$ (4) $4g$
6. A train is moving with a speed of 12 m/s on rails which are 1.5 m apart. To negotiate a curve radius 400 m, the height by which the outer rail should be raised with respect to the inner rail is (Given, $g = 10 \text{ m/s}^2$) :
- (1) 6.0 cm (2) 5.4 cm (3) 4.8 cm (4) 4.2 cm

7. Which of the following circuits is reverse - biased ?

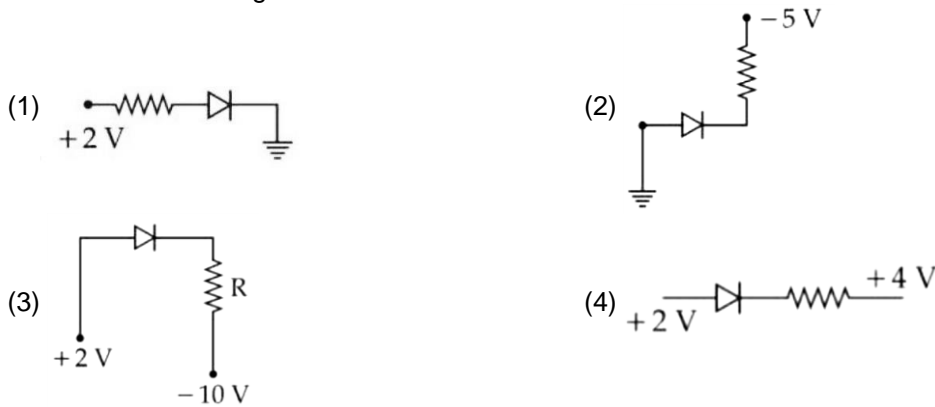

8. Identify the physical quantity that cannot be measured using spherometer :

- (1) Radius of curvature of concave surface (2) Specific rotation of liquids
 (3) Thickness of thin plates (4) Radius of curvature of convex surface

9. Two bodies of mass 4 g and 25 g are moving with equal kinetic energies. The ratio of magnitude of their linear momentum is :

- (1) 3 : 5 (2) 5 : 4 (3) 2 : 5 (4) 4 : 5

10. 0.08 kg air is heated at constant volume through 5°C. The specific heat of air at constant volume is 0.17kcal/kg°C and J = 4.18 joule/cal. The change in its internal energy is approximately.

- (1) 318 J (2) 298 J (3) 284 J (4) 142 J

11. The radius of third stationary orbit of electron for Bohr's atom is R. The radius of fourth stationary orbit will be:

- (1) $\frac{4}{3}R$ (2) $\frac{16}{9}R$ (3) $\frac{3}{4}R$ (4) $\frac{9}{16}R$

12. A rectangular loop of length 2.5 m and width 2 m is placed at 60° to a magnetic field of 4 T. The loop is removed from the field in 10sec. The average emf induced in the loop during this time is

- (1) -2 V (2) +2 V (3) +1 V (4) -1 V

13. An electric charge $10^{-6}\mu\text{C}$ is placed at origin (0,0) m of X – Y co-ordinate system. Two points P and Q are situated at $(\sqrt{3}, \sqrt{3})\text{m}$ and $(\sqrt{6}, 0)\text{m}$ respectively. The potential difference between the points P and Q will be :

- (1) $\sqrt{3} \text{ V}$ (2) $\sqrt{6} \text{ V}$ (3) 0 V (4) 3 V

14. A convex lens of focal length 40 cm forms an image of an extended source of light on a photoelectric cell. A current I is produced. The lens is replaced by another convex lens having the same diameter but focal length 20 cm. The photoelectric current now is :

- (1) $\frac{I}{2}$ (2) 4 I (3) 2 I (4) I

15. A body of mass 1000 kg is moving horizontally with a velocity 6 m/s. If 200 kg extra mass is added, the final velocity (in m/s) is:

- (1) 6 (2) 2 (3) 3 (4) 5

16. A plane electromagnetic wave propagating in x-direction is described by $E_y = (200\text{Vm}^{-1})\sin[1.5 \times 10^7t - 0.05x]$;

The intensity of the wave is :

(Use $\epsilon_0 = 8.85 \times 10^{-12}\text{C}^2 \text{N}^{-1} \text{m}^{-2}$)

- (1) 35.4Wm^{-2} (2) 53.1Wm^{-2} (3) 26.6Wm^{-2} (4) 106.2Wm^{-2}

17. Given below are two statements :
- Statement (I) : Planck's constant and angular momentum have same dimensions.
Statement (II) : Linear momentum and moment of force have same dimensions.
In the light of the above statements, choose the correct answer from the options given below :
- (1) Statement I is true but Statement II is false
(2) Both Statement I and Statement II are false
(3) Both Statement I and Statement II are true
(4) Statement I is false but Statement II is true
18. A wire of length 10 cm and radius $\sqrt{7} \times 10^{-4}$ m connected across the right gap of a meter bridge. When a resistance of 4.5Ω is connected on the left gap by using a resistance box, the balance length is found to be at 60 cm from the left end. If the resistivity of the wire is $R \times 10^{-7}\Omega\text{m}$, then value of R is :
- (1) 63 (2) 70 (3) 66 (4) 35
19. A wire of resistance R and length L is cut into 5 equal parts. If these parts are joined parallelly, then resultant resistance will be :
- (1) $\frac{1}{25}R$ (2) $\frac{1}{5}R$ (3) 25R (4) 5R
20. The average kinetic energy of a monatomic molecule is 0.414eV at temperature :
(Use $K_B = 1.38 \times 10^{-23}$ J/mol - K)
- (1) 3000 K (2) 3200 K (3) 1600 K (4) 1500 K

SECTION-B

21. A particle starts from origin at $t = 0$ with a velocity $5\hat{i}\text{m/s}$ and moves in $x - y$ plane under action of a force which produces a constant acceleration of $(3\hat{i} + 2\hat{j})\text{m/s}^2$. If the x -coordinate of the particle at that instant is 84 m, then the speed of the particle at this time is $\sqrt{\alpha}\text{m/s}$. The value of α is
22. A thin metallic wire having cross sectional area of 10^{-4} m^2 is used to make a ring of radius 30 cm. A positive charge of $2\pi\text{C}$ is uniformly distributed over the ring, while another positive charge of 30 pC is kept at the centre of the ring. The tension in the ring is N; provided that the ring does not get deformed (neglect the influence of gravity). (given, $\frac{1}{4\pi\epsilon_0} = 9 \times 10^9$ SI units)
23. Two coils have mutual inductance 0.002H. The current changes in the first coil according to the relation $i = i_0 \sin \omega t$, where $i_0 = 5$ A and $\omega = 50\pi$ rad/s. The maximum value of emf in the second coil is $\frac{\pi}{\alpha}$ V. The value of α is
24. Two immiscible liquids of refractive indices $\frac{8}{5}$ and $\frac{3}{2}$ respectively are put in a beaker as shown in the figure. The height of each column is 6 cm. A coin is placed at the bottom of the beaker. For near normal vision, the apparent depth of the coin is $\frac{\alpha}{4}$ cm. The value of α is

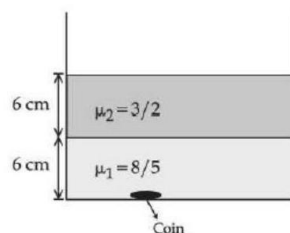

25. In a nuclear fission process, a high mass nuclide ($A \approx 236$) with binding energy 7.6 MeV/Nucleon dissociated into middle mass nuclides ($A \approx 118$), having binding energy of 8.6MeV/Nucleon. The energy released in the process would be MeV.
26. Four particles each of mass 1 kg are placed at four corners of a square of side 2 m. Moment of inertia of system about an axis perpendicular to its plane and passing through one of its vertex is kgm^2 .

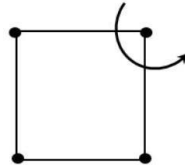

27. A particle executes simple harmonic motion with an amplitude of 4 cm. At the mean position, velocity of the particle is 10 cm/s. The distance of the particle from the mean position when its speed becomes 5 cm/s is $\sqrt{\alpha}\text{cm}$, where $\alpha =$
28. Two long, straight wires carry equal currents in opposite directions as shown in figure. The separation between the wires is 5.0 cm. The magnitude of the magnetic field at a point P midway between the wires is μT . (Given : $\mu_0 = 4\pi \times 10^{-7}\text{TmA}^{-1}$)

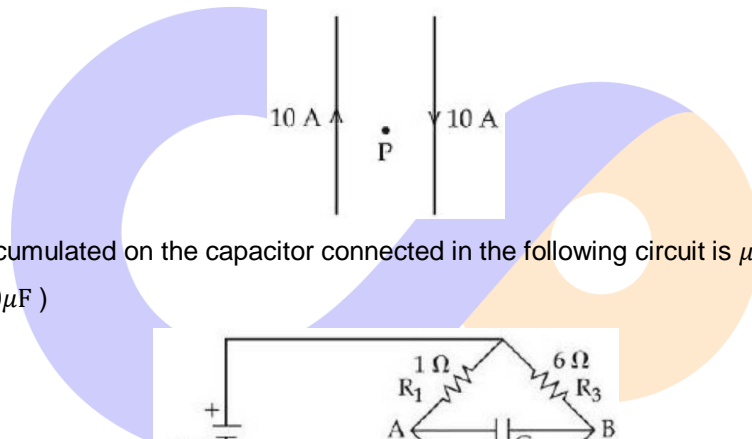

29. The charge accumulated on the capacitor connected in the following circuit is μC (Given $C = 150\mu\text{F}$)

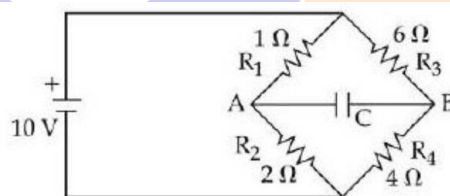

30. If average depth of an ocean is 4000 m and the bulk modulus of water is $2 \times 10^9\text{Nm}^{-2}$, then fractional compression $\frac{\Delta V}{V}$ of water at the bottom of ocean is $\alpha \times 10^{-2}$. The value of α is (Given, $g = 10 \text{ms}^{-2}$, $\rho = 1000 \text{kg m}^{-3}$)

NTA ANSWERS

- | | | | | | | | | | | | | | |
|-----|-------|-----|-----|-----|------|-----|-------|-----|------|-----|------|-----|-------|
| 1. | (4) | 2. | (2) | 3. | (1) | 4. | (3) | 5. | (4) | 6. | (2) | 7. | (4) |
| 8. | (2) | 9. | (3) | 10. | (3) | 11. | (2) | 12. | (3) | 13. | (3) | 14. | (4) |
| 15. | (4) | 16. | (2) | 17. | (1) | 18. | (3) | 19. | (1) | 20. | (2) | 21. | (673) |
| 22. | (3) | 23. | (2) | 24. | (31) | 25. | (236) | 26. | (16) | 27. | (12) | 28. | (160) |
| 29. | (400) | 30. | (2) | | | | | | | | | | |